



Designation: D5767 – 17

Standard Test Method for Instrumental Measurement of Distinctness-of-Image (DOI) Gloss of Coated Surfaces¹

This standard is issued under the fixed designation D5767; the number immediately following the designation indicates the year of original adoption or, in the case of revision, the year of last revision. A number in parentheses indicates the year of last reapproval. A superscript epsilon (ϵ) indicates an editorial change since the last revision or reapproval.

1. Scope

1.1 These test methods describe the measurement of the distinctness-of-image (DOI) gloss of coating surfaces using electro-optical measuring techniques.

1.2 The coatings assessed shall be applied to planar rigid surfaces.

1.3 *Test Method*—The light through a small slit is projected on the specimen surface and its reflected image intensity is measured through a sliding combed shutter to provide a value of image clarity.

1.4 The values stated in SI units are to be regarded as standard. No other units of measurement are included in this standard.

1.5 *This standard does not purport to address all of the safety concerns, if any, associated with its use. It is the responsibility of the user of this standard to establish appropriate safety, health and environmental practices and determine the applicability of regulatory limitations prior to use.*

1.6 *This international standard was developed in accordance with internationally recognized principles on standardization established in the Decision on Principles for the Development of International Standards, Guides and Recommendations issued by the World Trade Organization Technical Barriers to Trade (TBT) Committee.*

2. Referenced Documents

2.1 *ASTM Standards*:²

[D523 Test Method for Specular Gloss](#)

[D823 Practices for Producing Films of Uniform Thickness of Paint, Varnish, and Related Products on Test Panels](#)

[D2457 Test Method for Specular Gloss of Plastic Films and Solid Plastics](#)

¹ This test method is under the jurisdiction of ASTM Committee E12 on Color and Appearance and is the direct responsibility of Subcommittee E12.03 on Geometry.

Current edition approved June 15, 2017. Published September 2017. Originally approved in 1995. Last previous edition approved in 2012 as D5767 – 95 (2012). DOI: 10.1520/D5767-17.

² For referenced ASTM standards, visit the ASTM website, www.astm.org, or contact ASTM Customer Service at service@astm.org. For *Annual Book of ASTM Standards* volume information, refer to the standard's Document Summary page on the ASTM website.

[D3964 Practice for Selection of Coating Specimens for Appearance Measurements](#)

[D4039 Test Method for Reflection Haze of High-Gloss Surfaces](#)

[E284 Terminology of Appearance](#)

[E430 Test Methods for Measurement of Gloss of High-Gloss Surfaces by Abridged Goniophotometry](#)

[E691 Practice for Conducting an Interlaboratory Study to Determine the Precision of a Test Method](#)

2.2 *ISO Standards*:³

[ISO 10216 Anodizing of aluminum and its alloys—Instrumental determination of image clarity of anodic oxidation coatings—Instrumental method](#)

[ISO 17221 Plastics—Determination of image clarity \(degree of sharpness of reflected or transmitted image\)](#)

3. Terminology

3.1 *Definitions*—Terms and definitions in Terminology E284 are applicable to these methods.

3.1.1 *distinctness-of-image (DOI) gloss, n*—aspect of gloss characterized by the sharpness of images of objects produced by reflection at a surface. E284

3.1.1.1 *Discussion*—This quality is sometimes called image clarity.

3.1.2 *gloss reflectance factor, R_{s, n}*—ratio of the specularly reflected part of the (whole) flux reflected from the specimen to the flux reflected from a specified gloss standard under the same geometric and spectral conditions of measurements. E284

3.1.2.1 *Discussion*—The gloss standard may be a black glass or mirror and may be assigned one of a variety of scale values as specified.

3.1.3 *specular angle, n*—angle of reflection equal and opposite to the angle of incidence. E284

4. Significance and Use

4.1 An important aspect of the appearance of glossy coating surfaces is the distinctness (clarity) of images reflected by

³ Available from American National Standards Institute (ANSI), 25 W. 43rd St., 4th Floor, New York, NY 10036, <http://www.ansi.org>.

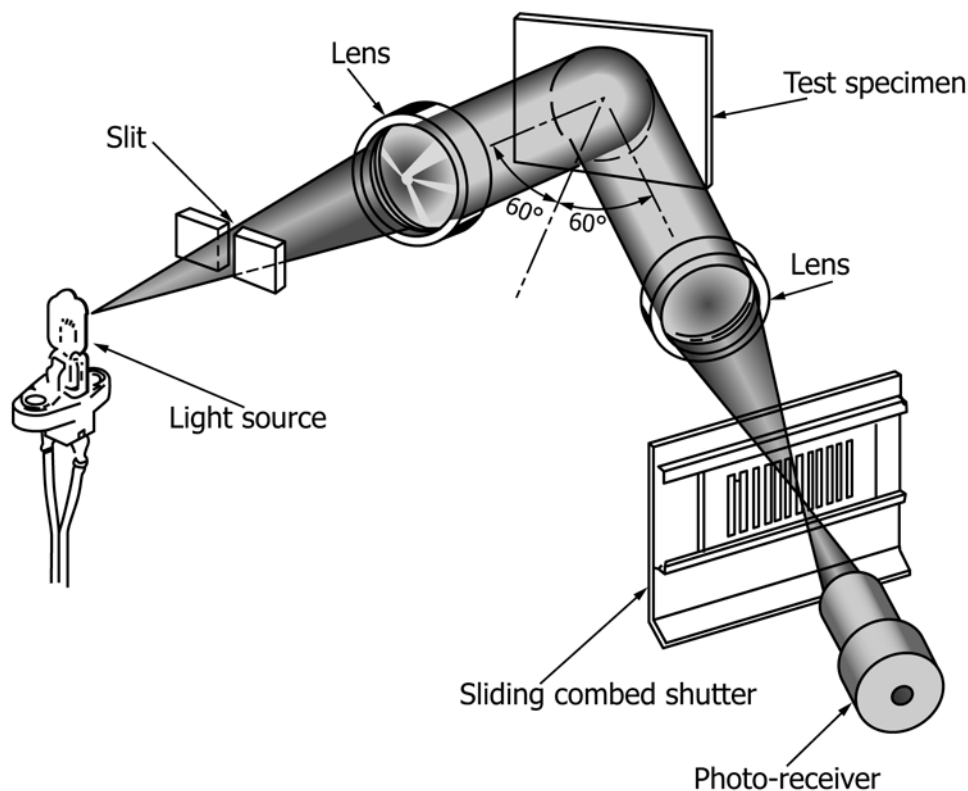

- DIMENSIONS HA-ICM
 A—Slit—0.1 mm
 B—Light Angle—22°
 C—Slit/Lens Dist.—50 mm
 D—Lens—f 50 mm
 E—Lens/Test Spec. Dist.—50 mm
 F—Test Spec./Lens Dist.—50 mm
 G—Lens—f 50 mm
 H—Lens/Com. Shut. Dist.—50 mm
 I—Light Angle—22°
 J—Shut./Slit Length—10 mm
 K—Shut./Slit Width—0.5 mm
 L—Shut./Slit Space—0.5 mm

FIG. 1 Diagrammatic Representation of Image Clarity Measurement

them. The values obtained in this measuring procedure correlate well with visual ratings for DOI (image clarity).

4.2 Although Test Methods D523 and D4039 are useful in characterizing some aspects of glossy appearance, they do not provide satisfactory ratings for DOI (image clarity).

4.3 The measurement conditions given conform to the conditions specified in Test Methods E430.

4.4 The measurement conditions given in this test method conform to the conditions specified in ISO 10216.

4.5 The scale values obtained with the measuring procedures of this test method range from 0 to 100 with a value of 100 representing perfect DOI (image clarity).

4.6 The DOI (image clarity) scale value does not, of itself, indicate any specific cause for reduction in reflected image sharpness. Surface irregularities such as haze, orange peel, and wrinkle, when present, may be cited as causes for reduction of image sharpness.

5. Apparatus

5.1 *Image Clarity Meter*,⁴ consisting of a light source, a sliding combed shutter, a photo-receiver, and a device for analyzing image intensities (see Fig. 1).

5.2 *Principle*—The light through a small slit is projected on the specimen surface and its reflected image intensity through a sliding combed shutter is measured.

5.3 *Geometric Conditions*—The axis of the incident beam shall be 60° from the perpendicular to the specimen surface and the photo-receiver shall be at the mirror reflection of the axis of the incident beam. The source slit is 0.1 ± 0.02 mm in width

⁴ The sole source of supply of the meter Model HA-ICM, Image Clarity, known to the committee at this time is Suga Test Instruments Co., Ltd., 4-14, Shinjuku 5-chome, Shinjuku-ku, Tokyo, 160 Japan. If you are aware of alternative suppliers, please provide this information to ASTM International Headquarters. Your comments will receive careful consideration at a meeting of the responsible technical committee,¹ which you may attend.